

WDB1 and WDB2 Series Bearing Temperature Sensors

APPLICATION

For use on any application where bearing temperature monitoring is desired or required.

METHOD OF OPERATION

The WDB 1 & 2 series is a range of bearing sensors manufactured to screw directly into a bearing housing through the existing 1/8" NPT threaded grease zerk. Each sensor is fitted with a grease zerk to allow lubrication of the bearing without the need for removal of the sensor. Three versions are available, a NTC thermistor or platinum RTD type for continuous temperature monitoring, and a PTC thermistor model with the following trip points (specify when ordering): 122°F, 140°F, 158°F, 176°F, 194°F. The sensor is supplied with a nine foot attached cable and can be connected to a PLC or to a hazard monitoring system, such as 4B's T500 Hotbus Elite, Watchdog Elite, or T400 Elite. The connections are not polarity sensitive therefore special connection requirements are eliminated, and the cable can be extended in the field.

FEATURES

- ▶ Screw in Positive Mount Installation
- ▶ Grease Zerk for Bearing Lubrication
- ▶ 1/2" NPT Conduit Entry (Steel Body)
- ▶ NTC Version – Continuous Temperature
- ▶ PTC Version – Trip Points from 122°F to 194°F
- ▶ PT100 Version – Platinum RTD
- ▶ Class 2 Div 1, Div 2 Approved

PART NUMBERS

- Brass Body Version

- ▶ WDB10V3C – NTC Type (Continuous)
- ▶ WDB11V3C – PTC Type (122°F Trip)
- ▶ WDB12V3C – PTC Type (140°F Trip)
- ▶ WDB13V3C – PTC Type (158°F Trip)
- ▶ WDB14V3C – PTC Type (176°F Trip)
- ▶ WDB15V3C – PTC Type (194°F Trip)
- ▶ WDB40V3AI – PT100 Type (Continuous)

- Steel Body Version

- ▶ WDB20V3C – NTC Type (Continuous)
- ▶ WDB21V3C – PTC Type (122°F Trip)
- ▶ WDB22V3C – PTC Type (140°F Trip)
- ▶ WDB23V3C – PTC Type (158°F Trip)
- ▶ WDB24V3C – PTC Type (176°F Trip)
- ▶ WDB25V3C – PTC Type (194°F Trip)
- ▶ WDB50V3A – PT100 Type (Continuous)



ATEX Approved Versions Available

Detailed specification, wiring diagrams and installation/operating instructions available immediately upon request.

Please refer to instruction manual for correct installation. Information subject to change or correction. March 2008.

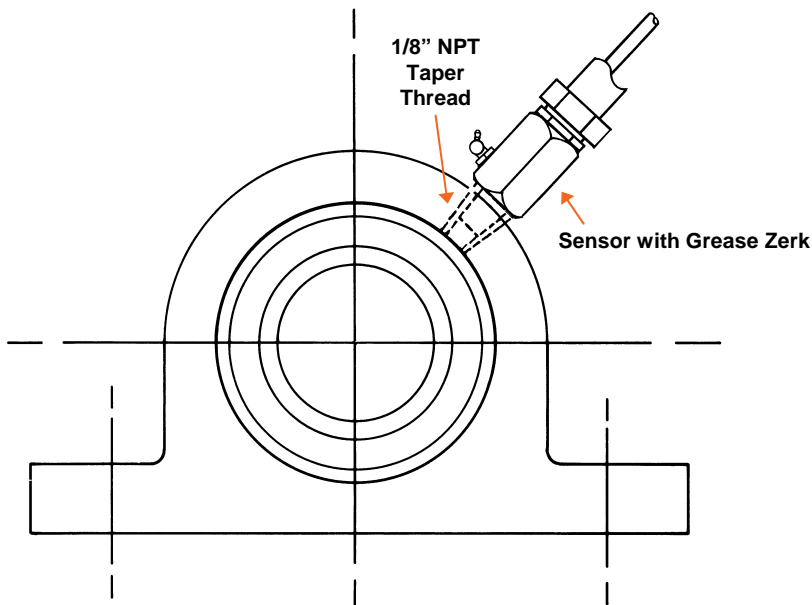

Installation of Bearing Temperature Sensor

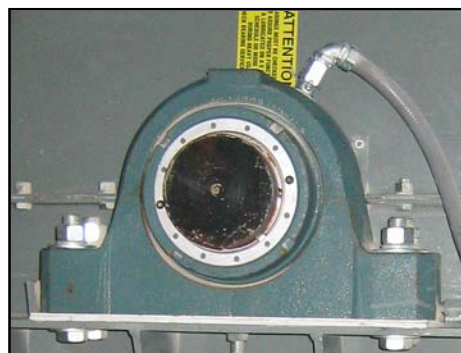

Bearing Sensor on Belt Conveyor



Example of Bearing Failure

TECHNICAL SPECIFICATIONS

WDB1 and WDB2 Series Bearing Temperature Sensors

NTC Sensors	
Resistance at 77°F:	10,000 Ohms
Resistance at 140°F:	2,487 Ohms
Resistance at 194°F:	916 Ohms
Sensing Voltage:	5 to 24 VDC
Current Draw:	1 ma

PTC Sensors	
Resistance at 140°F:	≤ 250 Ohms
Resistance at Trip Point:	≥ 2,000 Ohms
Sensing Voltage:	5 to 25 VDC
Current Draw:	20 ma

PT100 Sensors	
Resistance at 32°F:	100 Ohms
Resistance at 212°F:	138.4 Ohms
Sensing Voltage:	Via Transducer
Current Limit:	1 ma

NOTE: WDB Series 1 sensors have brass bodies and do not have conduit entries. WDB Series 2 sensors are plated steel bodies with 1/2" NPT conduit entries and are Class 2 Div 1 Groups E, F, and G approved. Both WDB Series 1 and 2 are available in three sensor versions, NTC, PTC or PT100.

Temperature Sensors can be used with the following 4B Hazard Monitoring Systems



T500 Hotbus Elite



Watchdog Elite



T400 Elite

Please refer to instruction manual for correct installation. Information subject to change or correction. March 2008.