

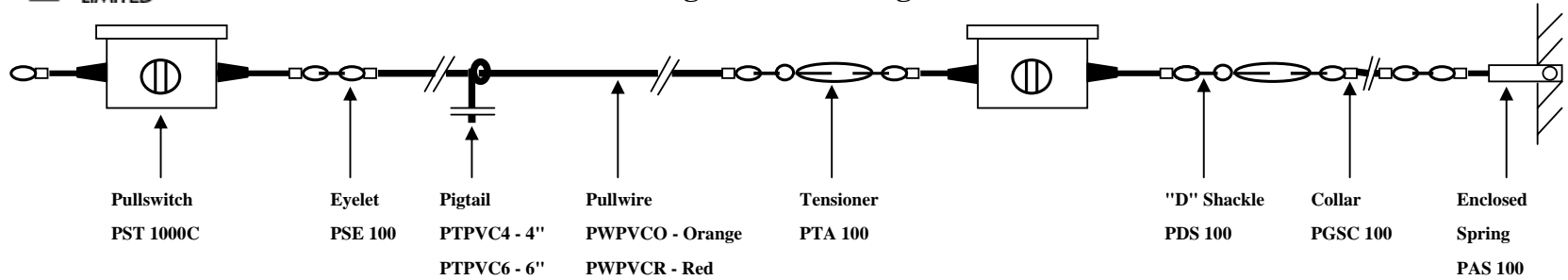

Conveyor Safety Pullswitch General Arrangement Drawing



Specifications

- Enclosure:** Makralon and Stainless Steel
- Weight:** 4lbs (1.8Kgs)
- Dimensions:** 4"x 8"x 5" (100 x 200 x 125mm)
- Protection:** IP65 / NEMA 4, 4X, 9 (dust & water tight)
Class II, Division 1, Groups E, F, G
- Contacts:** 5A , 240v AC
- Conduit Entries:** Two 1/2" NPT
- Mechanism:** Double ended tautwire
- CSA Approval:** Contract No 234829
ClassII:Div1: Groups E,FG:T5

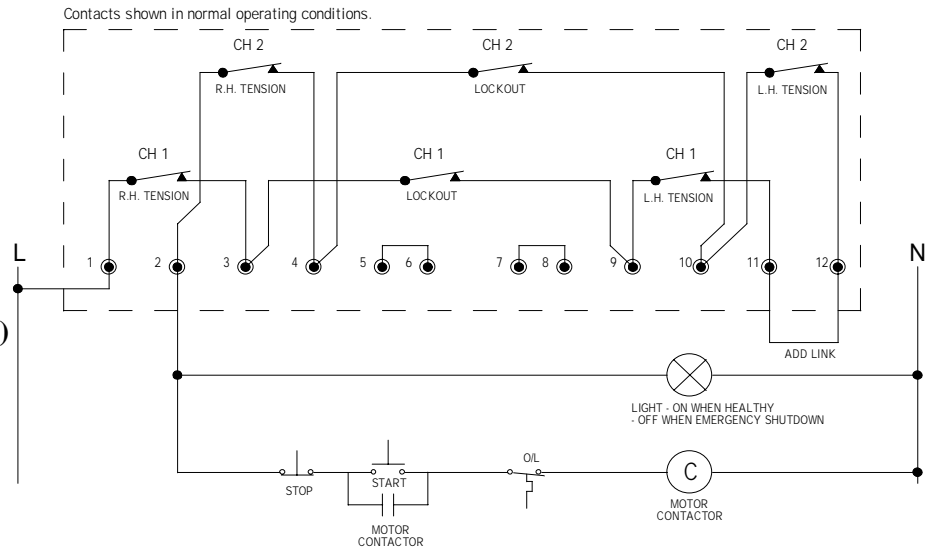



Pullswitch Installation / Operating Instructions

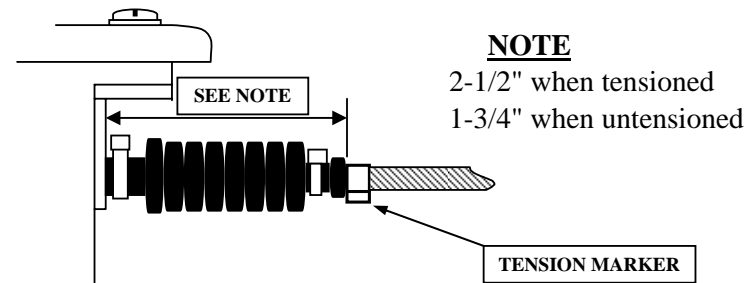
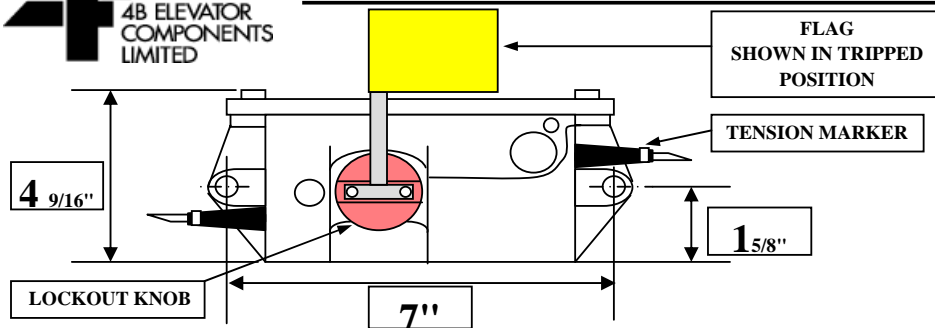

SYSTEM INSTALLATION (See general arrangement drawing over)

- 1) Bolt the Pullswitch onto the conveyor structure, using 3/8" bolts, so that the pullwire runs along the length of the conveyor and is easily accessible. If a tripper is used on the conveyor be careful to avoid its line of travel.
Align the Pullswitch and tighten the bolts. **(DO NOT OVER TIGHTEN)**
- 2) Unscrew the 2 top cover fixing screws and remove the cover.
- 3) Install 1/2" NPT Sealtite or rigid conduit. Use 1/2" NPT blanking plug on any unused conduit entry.
- 4) Pull incoming and outgoing electrical cable. Wire to the terminals according to the circuit diagram **located under the pullswitch top cover. (see drawing over)**
- 5) Make sure the electrical cables are cut to minimum lengths.
- 6) Fit pullwire and support with guides (pigtailed or eyebolts) at 9ft intervals along the length of the system.
- 7) Fit cable tensioners at each end and between multiple pullswitches.
- 8) Set tension of the pullwire by adjusting the cable tension adjuster until the tension marker is 2-1/2" from the side of the pullswitch. **(See diagram above)**

OPERATING INSTRUCTIONS

- 1) Stop the system by pulling the pullwire firmly to the full limit of travel or by turning the red switch on the front of the pullswitch clockwise until it snaps round into the horizontal position
- 2) Reset the system by turning the red switch counter clockwise to its original position. If the system does not reset, then check the tension of the cable.

Warning:

Inspect and check the operation of the system at regular intervals (3 - month intervals max)